

ULTRAWELD Installation Instructions

FBS Connection Type Flexible Butt End Splice of Horizontal Cables



PRECAUTIONS:

Follow General Safety & Preparation of Cable instructions on the backside of this sheet.

GENERAL WELDING PROCEDURE:

1. Check mold tag for conductors to be welded and proper weld metal cartridge size to use.
2. Make sure all surfaces and conductors are clean, dry and are the proper sizes for the mold's application per mold tag.
3. Molds can be dried by heating to approximately 250°F. Molds may be dried with a hand operated propane torch.
4. Position mold onto conductor(s). Lock mold with handle clamps or frame, whichever is the case.

5A. For UltraShot Drop-In process

- Insert UltraShot cartridge into mold.
- Close lid and attach Drone cord to UltraShot igniter.
- Before igniting, verify conductor positioning and that mold is closed completely.
- Push and hold both ignitor buttons at the same time until audible alert is heard

5B. For NUWtube Pour & Shoot process

- Insert steel disk being sure it is directly centered over the tap hole. Failure to insert disk into mold will create improper welds and spewing of weld metal.
- Pour cartridge or cartridges into the crucible being careful not to upset the steel disk. Tap bottom of cartridge to loosen all starting powder and spread 2/3 of the powder evenly over the top of the welding powder. Close the mold lid and pour the remaining starting powder into the ignition pocket on top of mold lid.
- Before igniting, verify conductor positioning and that mold is closed completely.
- Close cover and ignite starting powder with flint gun.
- Pull flint gun away quickly to prevent fouling flint.
- When necessary to hold down on mold cover use a long tool to keep hand away from flash of igniting powder.

6. Wait approximately 30 seconds before opening mold to permit metal to solidify.

FBS

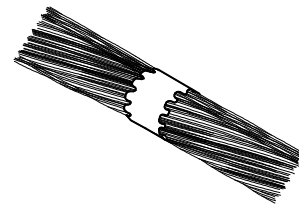

FBS WELDING PROCEDURE:

1. Strip any insulation from the conductors to be welded to a length that will allow them to fit at least halfway into the conductor hole of the mold.
2. Wrap high-temperature fiberglass tape over the bare conductors from where the insulation ends to the edge of the cavity inside the mold.

Note: Additional layers of fiberglass tape can be wrapped over the conductor to ensure snug mold fitment and prevent leakage. Too many wraps will hold the mold open which may lead to molten weld metal leakage and defective welds.

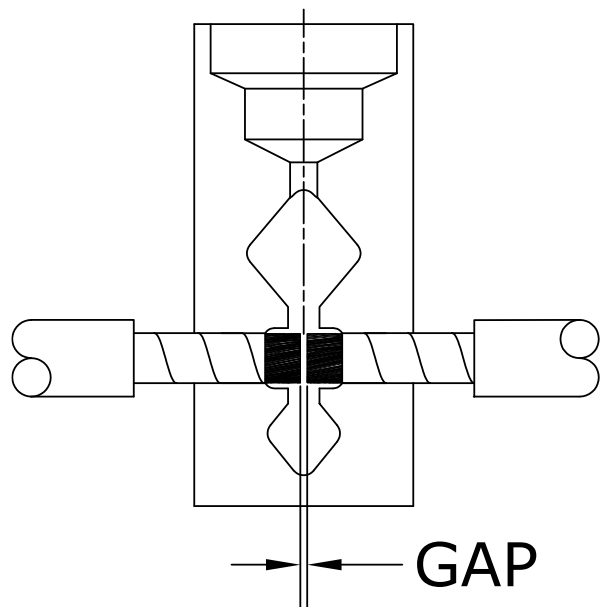

3. Place the conductors into the mold with a gap between the ends centered on the tap hole.

Note: After closing the mold, a flashlight can be used to look down the tap hole and ensure proper conductor positioning.

The size of the gap varies with conductor size and is also noted on the mold tag.

Smaller than 250 MCM	Gap = 1/16"
250 MCM and Larger	Gap = 1/8"

HARGER®

301 Ziegler Drive, Grayslake, IL 60030
Phone: 847-548-8700
Fax: 847-548-8755
Website: www.harger.com

ULTRAWELD Installation Instructions

FBS – Flexible Butt End Splice of Horizontal Cables Continued

GENERAL SAFETY INSTRUCTIONS:

1. Always wear proper clothing, safety glasses and gloves when exothermic welding.
2. Only weld items that the mold is designed for.
3. Do not use worn or broken molds which could cause leakage of molten weld metal.
4. Make sure that the conductors being welded fits in the mold properly and that the mold will close tightly around them.
5. Do not alter molds or accessories without factory authorization.
6. Avoid breathing concentrations of smoke, as it may be hazardous to your health.
7. Avoid contact with hot materials.
8. Remove or protect fire hazards in the welding area.
9. Avoid moisture and contaminants in the mold and conductors being welded. Contact of molten weld metal with moisture or contaminants may cause weld metal to spew out of mold.
10. Failure to abide by the above and follow welding procedures may result in improper welds, damage to the material being welded or create hazardous situations for the individual.

MOLD CARE:

- Do not use a wire brush to clean mold
- Do not use a screwdriver to clean the mold
- Clean mold with soft bristle mold cleaning brush to remove slag and residue
- Do not push conductor into a closed mold
- Store molds in a dry environment

GENERAL PREPARATION OF CABLE:

1. Cable must be bright, clean and dry.
2. Cable that is saturated with oil or grease must be cleaned. Cable may be cleaned by burning it off with a propane or oxy-acetylene torch. After burning off oil or grease, a wire brush should be used to remove residue. Wet cable must be dried out. Use a hand propane torch.
3. Corroded cable must be cleaned. Use the CCBRS2 cable cleaning brush or CCBRS1 card cloth brush. It is important that the ends of the individual strands are clean. This can best be accomplished by making a fresh cut on the end of the cable.
4. Cable should be straightened before clamping mold in place. Bent or out of round cable will hold mold open and cause leaks.
5. Remove insulation from insulated cable before cutting with hack saw. Otherwise ends of strands will become coated with insulating material which may cause defective welds.
6. FLEXIBLE CABLE: A sleeve must be used when welding flexible cable. WRPSLV wrap sleeves are recommended for 300 MCM and smaller cable.

POST WELD INSTRUCTIONS:

The conductors must not be damaged in the excess weld removal process. Remove the excess weld material with a grinder until the weld is round and smooth.

