

HARGER™

ULTRAWELD®

INSTRUCTIONS FOR ULTRAWELD® GROUNDING CONNECTIONS - CABLE TO RAIL

#RMFPT

1. See reverse side of preparation of cable and rail surfaces.
2. Place cable in mold and pack cable opening with duct seal when necessary.
3. Follow instructions on reverse side of this sheet for general welding instructions.

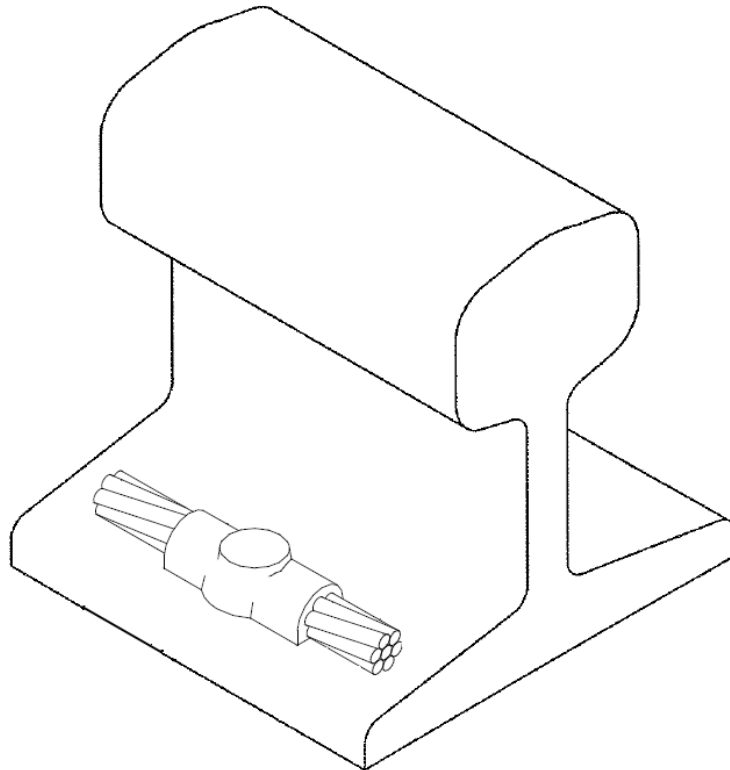
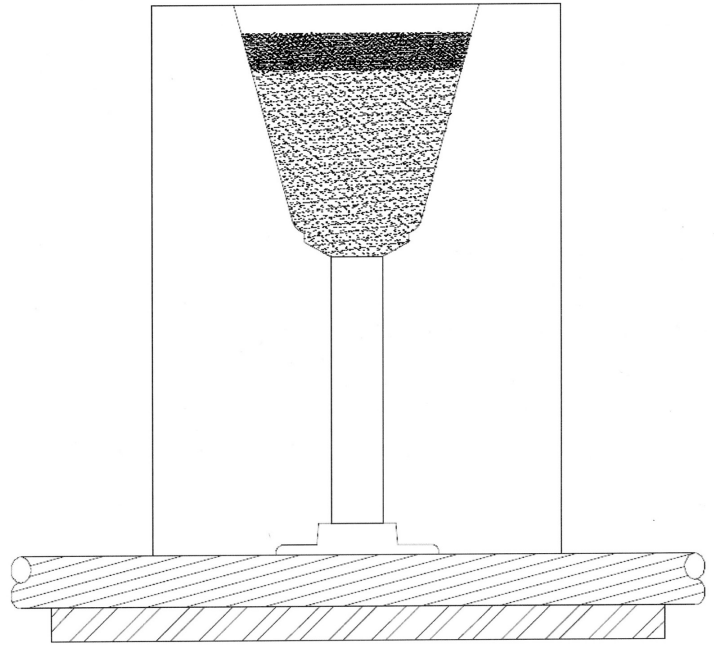

GENERAL SAFETY INSTRUCTIONS

1. Always wear proper clothing, safety glasses and gloves when exothermic welding.
2. Only weld items mold is designed for.
3. Do not use worn or broken molds which could cause leakage of molten weld metal.
4. Make sure that the material being welded fits in the mold properly and that the mold will close tightly around them.
5. Do not alter molds or accessories without factory authorization.
6. Avoid breathing concentrations of smoke, as it may be hazardous to your health.
7. Avoid contact with hot materials.
8. Remove or protect fire hazards in the welding area.
9. Avoid moisture and contaminants in the mold and materials being welded. Contact of molten weld metal with moisture or contaminants may cause weld metal to spew out of mold.
10. When welding to pipe or vessels, you should consider the following:
 - a. the effect welding may have on structural members and thin wall pipe or vessels.
 - b. pipe or vessels that are pressurized or contain (or have contained) flammable, explosive or hazardous materials should be evaluated in the case of a melt-through or hot molten weld metal coming in contact with any flammable, explosive or hazardous materials.
11. Failure to abide by the above and follow welding procedures may result in improper welds, damage to the material being welded or create hazardous situations for the individual.

PREPARATION OF CABLE

1. Cable must be bright, clean and dry.
2. Cable that is saturated with oil or grease must be cleaned. Cable may be cleaned by burning it off with a torch (gasoline blow torch, butane torch, acetylene torch). After burning off oil or grease, a wire brush should be used to remove residue. Wet cable must be dried out. Use a hand torch.
3. Corroded cable must be cleaned. Use the CCBRS11 cable cleaning brush or a card cloth brush. It is important that the ends of the individual strands are clean. This can best be accomplished by making a fresh cut on the end of the cable.
4. Cable should be straightened before clamping mold in place. Bent or out of round cable will hold mold open and cause leaks.
5. Remove insulation from insulated cable before cutting with hack saw. Otherwise ends of strands will become coated with insulating material which may cause defective welds.
6. FLEXIBLE CABLE
A sleeve must be used when welding flexible cable. CUWPSLV wrap sleeves are recommended for 300 MCM and smaller cable.

PREPARATION OF STEEL, CAST IRON OR RAIL

1. Surface to be welded must be bright clean and dry.
2. Remove rust and mill scale with rasp, coarse file or grinder.
3. Remove oil, grease or pitch coatings with a solvent or torch.
4. Galvanized surfaces may be cleaned with emery cloth to remove oxide film. It is not necessary to remove galvanizing unless it is double or triple galvanized
5. Cast iron surfaces must be free from large pits and flaws.

For cast iron less than 1/2" thick, do not use larger than a #65 cartridge.

NOTE: Use powder marked C.I. for cast iron. Do not use regular powder.

6. Under some conditions of temperature and humidity the surface to be welded will sweat causing porous welds. This can be eliminated by warming the surface with a hand torch prior to welding.

WELDING PROCEDURE

1. Check mold tag for material to be welded and proper cartridge size to use.
2. Make sure all surfaces and conductors are clean, dry and are the proper sizes for the mold's application per mold tag.
3. Molds can be dried by heating to approximately 250° F. Molds may be dried with a hand operated butane torch or by firing a charge in the mold before making the desired weld.
4. Position mold onto conductor(s). See front of this sheet for positioning of conductors into mold. Lock mold with handle clamps or frame, which ever is the case.
5. Insert steel disk being sure it is directly centered over the tap hole. Failure to insert disk into mold will create improper welds and spewing of weld metal.
6. Pour cartridge or cartridges into the crucible being careful not to upset the steel disk. Tap bottom of cartridge to loosen all starting powder and spread 2/3 of the powder evenly over the top of the welding powder. Close the lid of the mold and pour the remaining starting powder into the ignition pocket on top of mold lid.
7. Before igniting, verify conductor positioning and that mold is closed completely.
8. Close cover and ignite starting powder with flint gun. Pull flint gun away quickly to prevent fouling flint. When necessary to hold down on mold cover use a long tool to keep hand away from flash of igniting powder.
9. Wait approximately 30 seconds before opening mold to permit metal to solidify.
10. To clean the mold, use a natural bristle brush, soft cloth or newspaper before making next weld. On horizontally split molds, use a small diameter rod or screw driver to remove slag from tap hole. Caution should be used when cleaning molds to avoid burns from contact with hot mold.

DO NOT USE WIRE BRUSH TO CLEAN MOLD!

- NOTE:
1. A fouled flint gun may be cleaned by soaking in house hold ammonia.
 2. Proper cartridge size is marked on mold tag and shown on the bottom of the cartridge tube.
 3. Cartridge size is the approximate weight of the powder in grams. When the cartridge size specified is not available, two or more smaller cartridges or part of a larger cartridge may be used. Care should be taken not to mix starting material in-between cartridges.
 4. Handle Clamp adjustments may be made by removing cotter pin and clevis pin and turning eye bolt one turn clockwise to loosen or one turn counter clockwise to tighten.