

ULTRAWELD Installation Instructions

RO Connection Type Cross of Horizontal Cable Lapped Over Reinforcing Steel



PRECAUTIONS:

Follow General Safety, Preparation of Cable and Preparation of Ground Rod instructions on the backside of this sheet.

WELDING PROCEDURE:

1. Check mold tag for conductors to be welded and proper weld metal cartridge size to use.
2. Make sure all surfaces and conductors are clean, dry and are the proper sizes for the mold's application per mold tag.
3. Molds can be dried by heating to approximately 250°F. Molds may be dried with a hand operated propane torch.
4. Position mold onto conductor(s). Lock mold with handle clamps or frame, whichever is the case.

5A. For UltraShot Drop-In process

- Insert UltraShot cartridge into mold.
- Close lid and attach Drone cord to UltraShot igniter.
- Before igniting, verify conductor positioning and that mold is closed completely.
- Push and hold both ignitor buttons at the same time until audible alert is heard

5B. For NUWtube Pour & Shoot process

- Insert steel disk being sure it is directly centered over the tap hole. Failure to insert disk into mold will create improper welds and spewing of weld metal.
- Pour cartridge or cartridges into the crucible being careful not to upset the steel disk. Tap bottom of cartridge to loosen all starting powder and spread 2/3 of the powder evenly over the top of the welding powder. Close the mold lid and pour the remaining starting powder into the ignition pocket on top of mold lid.
- Before igniting, verify conductor positioning and that mold is closed completely.
- Close cover and ignite starting powder with flint gun.
- Pull flint gun away quickly to prevent fouling flint.
- When necessary to hold down on mold cover use a long tool to keep hand away from flash of igniting powder.

6. Wait approximately 30 seconds before opening mold to permit metal to solidify.

RO

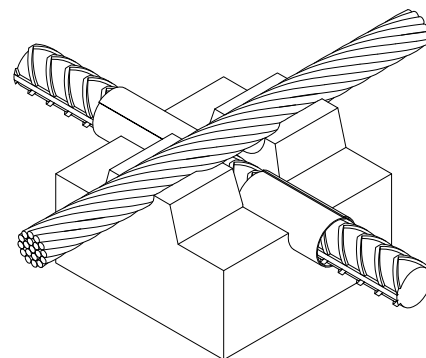
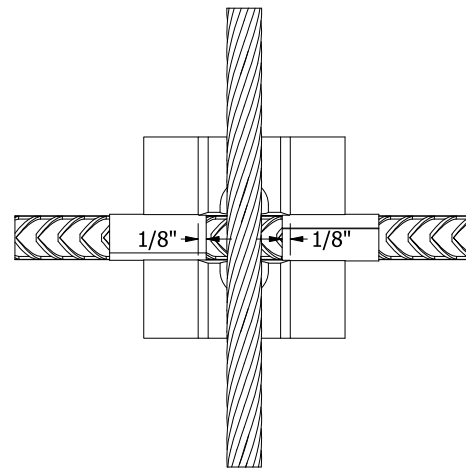
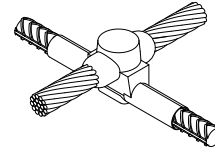

Place cable and reinforcing bar into the mold.

Follow instructions on reverse side for proper use of packing material.

HARGER®

301 Ziegler Drive, Grayslake, IL 60030
Phone: 847-548-8700
Fax: 847-548-8755
Website: www.harger.com

ULTRAWELD Installation Instructions

RO — Cross of Horizontal Cable Lapped Over Reinforcing Steel Continued

GENERAL SAFETY INSTRUCTIONS:

1. Always wear proper clothing, safety glasses and gloves when exothermic welding.
2. Only weld items that the mold is designed for.
3. Do not use worn or broken molds which could cause leakage of molten weld metal.
4. Make sure that the conductors being welded fits in the mold properly and that the mold will close tightly around them.
5. Do not alter molds or accessories without factory authorization.
6. Avoid breathing concentrations of smoke, as it may be hazardous to your health.
7. Avoid contact with hot materials.
8. Remove or protect fire hazards in the welding area.
9. Avoid moisture and contaminants in the mold and conductors being welded. Contact of molten weld metal with moisture or contaminants may cause weld metal to spew out of mold.
10. Failure to abide by the above and follow welding procedures may result in improper welds, damage to the material being welded or create hazardous situations for the individual.

MOLD CARE:

- Do not use a wire brush to clean mold.
- Do not use a screwdriver to clean the mold.
- Clean mold with soft bristle mold cleaning brush to remove slag and residue.
- Do not push conductor into a closed mold.
- Store molds in a dry environment.

PREPARATION OF CABLE:

1. Cable must be bright, clean and dry.
2. Cable that is saturated with oil or grease must be cleaned. Cable may be cleaned by burning it off with a propane or oxy-acetylene torch. After burning off oil or grease, a wire brush should be used to remove residue. Wet cable must be dried out. Use a hand propane torch.
3. Corroded cable must be cleaned. Use the CCBRS2 cable cleaning brush or CCBRS1 card cloth brush. It is important that the ends of the individual strands are clean. This can best be accomplished by making a fresh cut on the end of the cable.
4. Cable should be straightened before clamping mold in place. Bent or out of round cable will hold mold open and cause leaks.
5. Remove insulation from insulated cable before cutting with hack saw. Otherwise ends of strands will become coated with insulating material which may cause defective welds.
6. FLEXIBLE CABLE: A sleeve must be used when welding flexible cable. WRPSLV wrap sleeves are recommended for 300 MCM and smaller cable.

PREPARATION OF REINFORCING BAR:

NOTE: The use of Ultraweld exothermic connections on reinforcing bar can have an effect on the reinforcing bar's structural strength. Consideration as to weld location should be made prior to welding. Areas under minimum stress is preferred.

1. Surface to be welded must be bright, clean, and dry.
2. Remove rust and mill scale with coarse file or grinder.
3. Remove oil, grease, or pitch coatings with solvent or propane torch.

USING WRAP SLEEVES & PACKING PAD:

1. For molds requiring wrap sleeves, wrap the sleeve all the way around the bar. Wrap sleeve must encapsulate the bar to insure a tight seal between mold and bar. Too many wraps will hold the mold open and cause leakage.
2. For molds requiring packing pad, align slot in pad to slot in mold. Align edge of pad with edges of the mold. Secure backing plate when required.