

HCAJC1/2 (1)

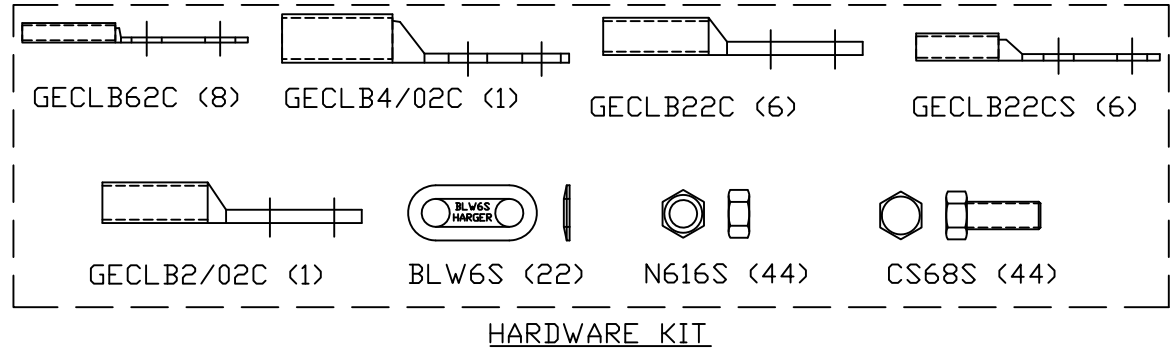
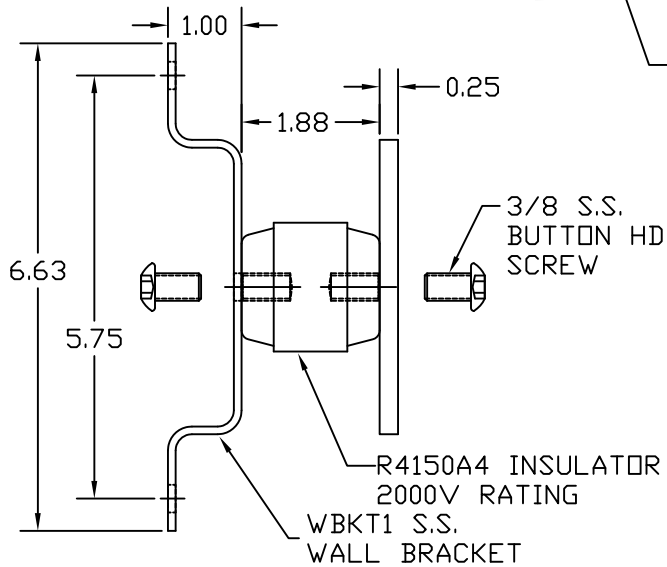
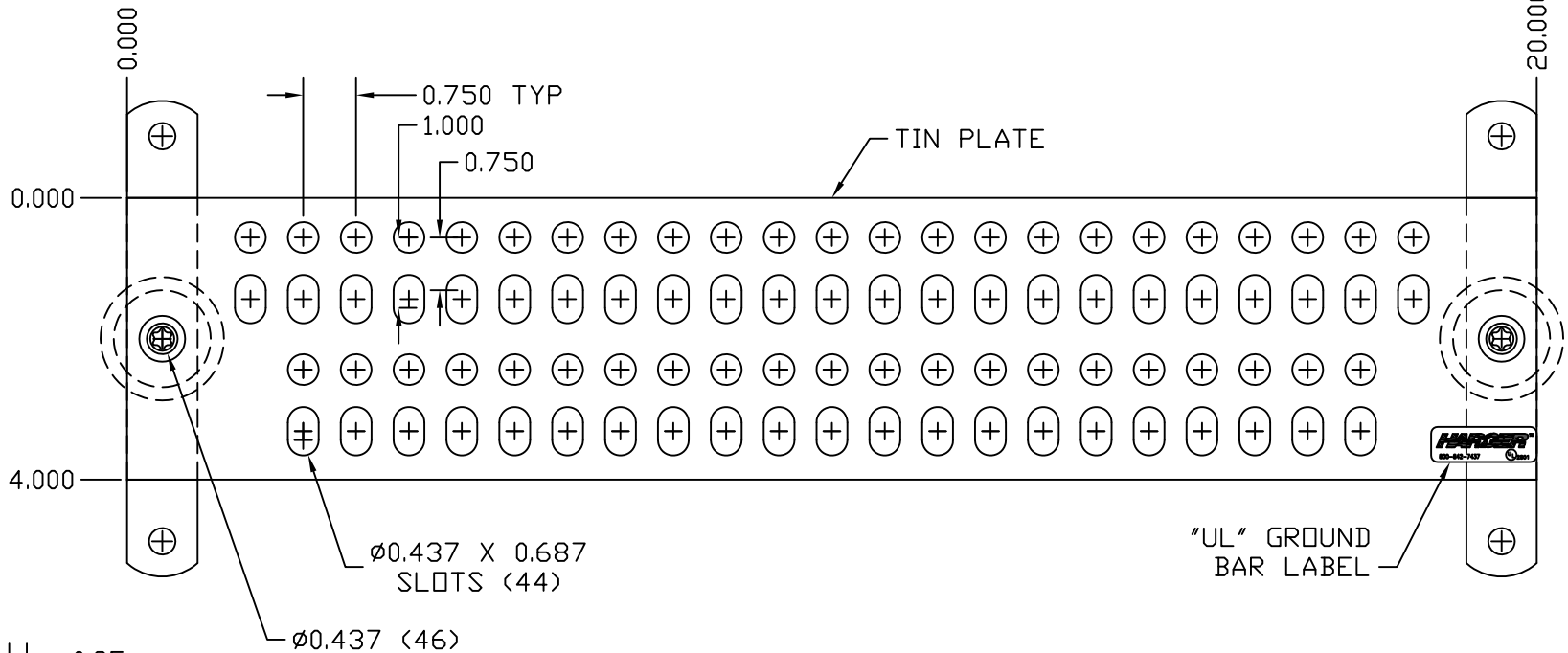

**COPPER GROUND BAR ASSEMBLY**

EST WT 10.8#

**APPROVED**

AS DRAWN: \_\_\_\_\_  
 AS NOTED: \_\_\_\_\_  
 DATE: \_\_\_\_\_

THIS DOCUMENT AND THE CONTENTS THEREOF IS THE PROPERTY OF HARGER INC., AND IS FURNISHED TO YOU FOR INFORMATION ONLY. THE INFORMATION CONTAINED HEREIN IS CONFIDENTIAL AND OF A PROPRIETARY NATURE AND MUST NOT BE DISCLOSED TO THIRD PARTIES WITHOUT THE EXPRESS WRITTEN APPROVAL OF HARGER INC.

A	REVISED KIT ECO 0136	032917	LAL
LET	REVISION	DATE	BY
TOLERANCES UNLESS NOTED: FRACTIONAL +/- 1/16 DECIMAL +/- .030 BREAK SHARP EDGES		3RD ANGLE PROJECTION	

**PART NO. TGBI14420MKT**  
GROUND BAR ASSEMBLY

DRAWN BY: LAL  
 CHECKED BY: \_\_\_\_\_  
 DATE: 102910



301 ZIEGLER DRIVE  
 GRAYSLAKE, IL 60030  
 (847) 548-8700

REVISION: A  
 SCALE: 3/8  
 SHEET: 1 OF 1