

(A)

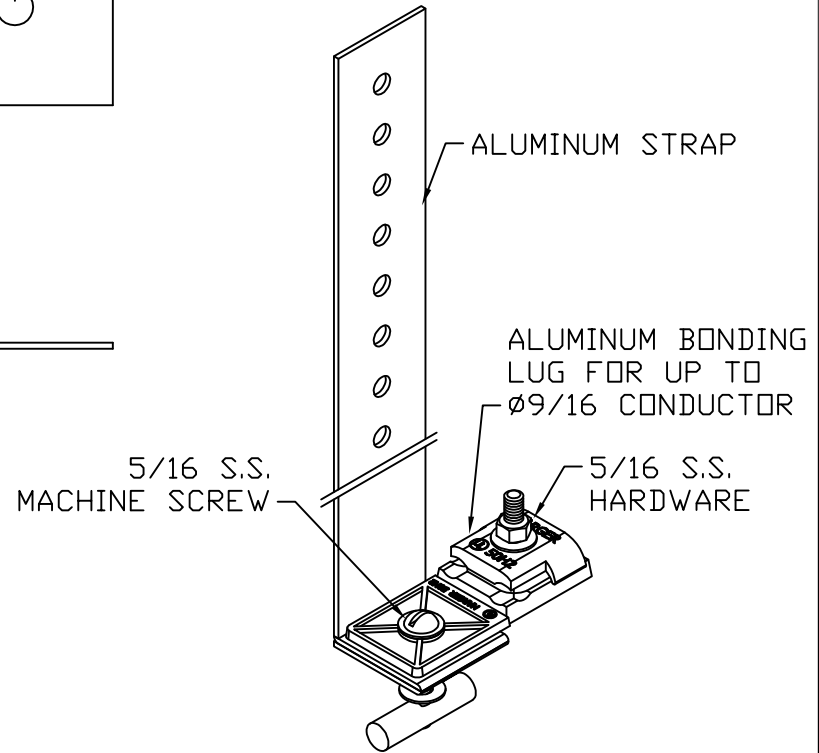
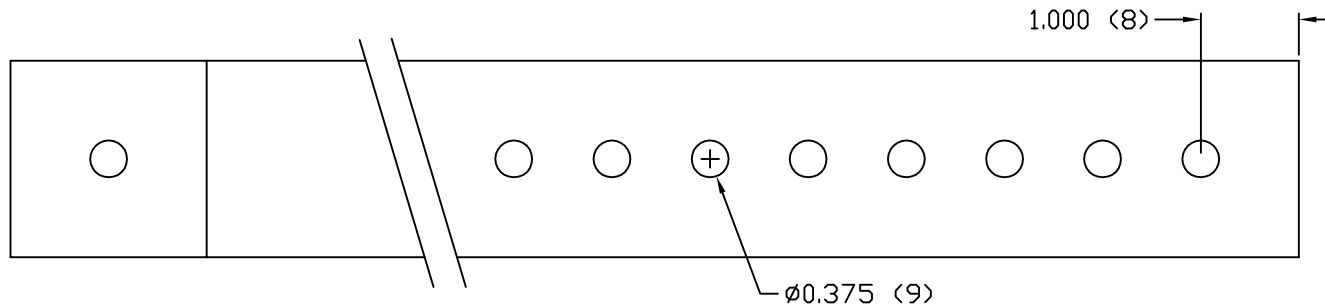

ALUMINUM STRAP PIPE CLAMP

6.50 - 8.625 ACTUAL DIAMETER

EST WT 1.2#

APPROVED

AS DRAWN: _____

AS NOTED: _____

DATE: _____

THIS DOCUMENT AND THE CONTENTS THEREOF IS THE PROPERTY OF HARGER INC., AND IS FURNISHED TO YOU FOR INFORMATION ONLY. THE INFORMATION CONTAINED HEREIN IS CONFIDENTIAL AND OF A PROPRIETARY NATURE AND MUST NOT BE DISCLOSED TO THIRD PARTIES WITHOUT THE EXPRESS WRITTEN APPROVAL OF HARGER INC.

C	REDESIGN BONDING LUG	050316	LAL
B	HAD A222 IN BOM; BROKE OUT	081808	DVB
A	WAS 30.50"	101600	KAB
LET	REVISION	DATE	BY
TOLERANCES UNLESS NOTED:		3RD ANGLE PROJECTION	
FRACTIONAL +/- 1/16		⊕	
DECIMAL +/- .030			
BREAK SHARP EDGES			

PART NO. A2318
STRAP PIPE CLAMP

DRAWN BY:
LAL

CHECKED BY:

DATE:
042299

HARGER™

301 ZIEGLER DRIVE
GRAYSLAKE, IL 60030
(847) 548-8700

REVISION:
C

SCALE:
1/2

SHEET:
1 OF 1