

BOTTOM

MIDDLE

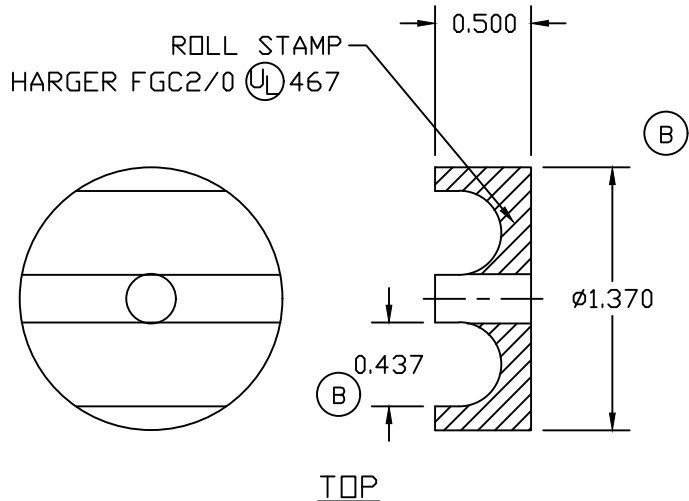

TOP

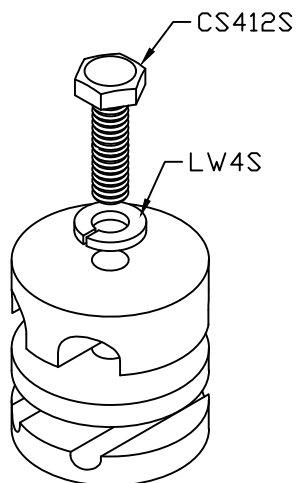

TIN PLATE

EST WT .3 LBS

APPROVED

AS DRAWN: _____
 AS NOTED: _____
 DATE: _____

THIS DOCUMENT AND THE CONTENTS THEREOF IS THE PROPERTY OF HARGER INC., AND IS FURNISHED TO YOU FOR INFORMATION ONLY. THE INFORMATION CONTAINED HEREIN IS CONFIDENTIAL AND OF A PROPRIETARY NATURE AND MUST NOT BE DISCLOSED TO THIRD PARTIES WITHOUT THE EXPRESS WRITTEN APPROVAL OF HARGER INC.

-	-	-	-
E	IDENTIFY CRITICAL DIMS	12/22/17	HR
D	REMOVED FGC2/OTOP	022608	LAL
C	ADDED FGC2/OTOP	111407	LAL
B	WAS .375 x .312 DEEP	110904	LAL
A	WAS 1 3/8 DIA. MAT'L	120400	LAL
LET	REVISION	DATE	BY
TOLERANCES UNLESS NOTED:		3RD ANGLE PROJECTION	
FRACTIONAL	+/- 1/16		
.00	+/- .03		
.000	+/- .010		

PART NO. FGC2/0
 FENCE GROUND CLAMP

DRAWN BY:
 LAL
 CHECKED BY:
 DATE:
 091101

HARGER™

301 ZIEGLER DRIVE
 GRAYSLAKE, IL 60030
 (847) 548-8700

REVISION:
 D
 SCALE:
 FULL
 SHEET:
 1 OF 1